

HELI

www.heliforklift.net

CBD30 -170HA

ELECTRIC PALLET TRUCK



越野小坦克

不惧挑战!

适用于工地、冷库
等复杂环境



300mm大直径
越野轮

CHARACTERISTICS: Compact and flexible, suitable for narrow place operations. Standard configuration of emergency stop switch, emergency reverse safety device and built-in charger. Multifunction handle, key, upright walking, LCD screen (can display battery, working time, fault code), Optional intergrated combination lock and turtle climbing, contributes to easy and comfortable operation. Metal shell-High strength, safer. Standard nylon load-bearing wheels, more durable in off-road condition. Fully sealed design, meets operational requirements. Adaptable to a variety of environments, stronger passability in complex conditions. Standard nylon load-bearing wheels, more durable in off-road condition. Fully sealed design, meets operational requirements. Adaptable to a variety of environments, stronger passability in complex conditions.



COMFORT AND
ENERGY SAVING



STABLE AND
RELIABLE



INTELLIGENT
SECURITY



CONVENIENT
MAINTENANCE

CBD30-170HA

HELI

Feature		单位	
1.1	Model		CBD30-170HA
1.2	Operating type		Pedestrian
1.3	Load capacity	kg	3000
1.4	Load center	mm	600
1.5	Wheel base	mm	1380
Wheels			
2.1	Wheels type		Driving:Rubber Bearing:Nylon
2.2	Driving/Bearing		1X+0/4
2.3	Driving wheel size	mm	φ300×110
2.4	Bearing wheel size	mm	φ84×80
Dimension			
3.1	Min.fork lowered height	mm	85
3.2	Max.fork lifting height	mm	205
3.3	Max.lifting height	mm	120
3.4	Outside width between forks	mm	560/685
3.5	Fork length	mm	1150/1200
3.6	Fork width	mm	170
3.7	Fork thickness	mm	75
3.8	Overall length	mm	1723/1773
3.9	Overall width	mm	697
3.10	Overall height(With handle)	mm	1382
3.11	Overall height(Without handle)		838
3.12	Min.Turning radius	mm	1578/1628
3.13	Min.Aisle width for pallets 800×1200	mm	1883/1933
3.14	Min.Aisle width for pallets 1000×1200	mm	1911/1961
Performance			
4.1	Travel speed,laden/unladen	km/h	3.5/4
4.2	Lift speed,laden/unladen	mm/s	17/23
4.3	Lowering speed,laden/unladen	mm/s	35/30
4.4	Gradeability,laden/unladen	%	10/20
4.5	Service brake type		Electric
Electrical configuration			
5.1	Traction motor rating at S2 60 min	kW	BLDC 1.8
5.2	Lift motor rating at S3 15%	kW	DC 0.8
5.3	Battery voltage / capacity	V/Ah	48/30 (VRLA) 48/65(Optional)
5.4	Charger specification	V/A	48/5 48/10
Weight			
6.1	Battery weight (±5%)	kg	9×4 15×4
6.2	Service weight with battery	kg	336 360
Others			
7.1	Steering type		Mechanical
7.2	驱动控制器		BLDC

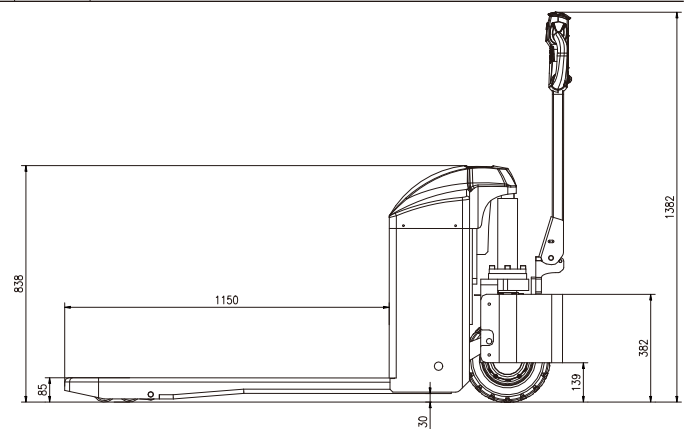
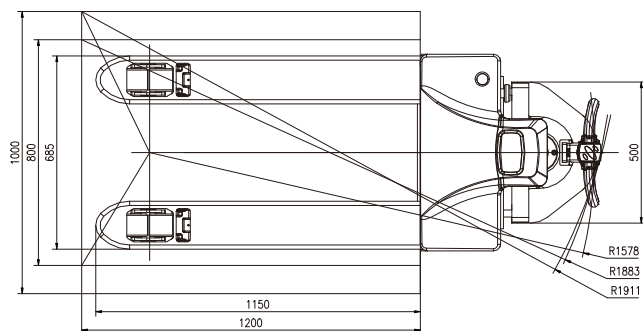

ANHUI HELI CO., LTD.

Add / No.668, FangXing Road, Hefei, China
 Fax / +86-551-63639966
 Tel / +86-551-63639068(America); 63639258(Europe);
 63639358(Asia); 63662105(Africa & Middle East)

