

# SJ3215/19 E

## ELECTRIC SCISSORS



### STANDARD FEATURES

- Drivable at full height
- Variable speed, dual front wheel electric drive
- 90° Steering (zero inside turning radius)
- Dual holding brakes
- SKYCODED™ Colour coded and numbered wiring system
- On-board visual interface with diagnostic capabilities
- Shroud style, impact resistant composite control box with extended cable
- Proportional controls for drive & lift functions
- 0.91 m Roll out extension deck
- 24V DC Power source
- Low voltage battery protection
- 25% Gradeability
- Solid rubber, non-marking tyres
- Pothole protection system
- 12.5 m/s Wind rating
- Tilt alarm with drive & lift cut-out (3.5° x 1.5°)
- Flashing light
- Lanyard attachment points
- Operator horn
- Forklift pockets and tie down / lift lugs
- Overload sensing system
- Fold down hinged railing system
- Half height spring hinged entry gate
- Low battery indicator light on control box
- Universal smart charger
- Single point emergency lowering
- Arm guard with slow close descend
- Telematics ready



- 16% operational carbon saving compared to previous model



- Up to 20% improvement in duty cycle



- ZERO emissions



- <70 dB inherently quiet machine operation (excl. alarms)
- White noise/broadband alarms - *optional*



- 90% recyclable (by weight)



- 60% less hydraulic connections – reduces leak potential
- ECOTRAY leak containment - *optional*
- Bio-degradeable hydraulic oil - *optional*



- Telematics – remote diagnostics reduces site visits (operational carbon footprint)

# SJ3215/19 E ELECTRIC SCISSORS

Dimensions	SJ3215 E	SJ3219 E
<b>A</b> Work Height	6.44 m	7.65 m
<b>B</b> Raised Platform Height	4.44 m	5.65 m
<b>C</b> Lowered Platform Height	0.91 m	1.03 m
<b>D</b> Overall Width	0.82 m	0.82 m
<b>E</b> Overall Length	1.80 m	1.80 m
<b>F</b> Stowed Height (Rails Up)	2.03 m	2.13 m
<b>G</b> Stowed Height (Rails Down)	1.67 m	1.79 m
<b>H</b> Platform Width (Inside Dimension)	0.66 m	0.66 m
<b>I</b> Platform Length (Inside Dimension)	1.55 m	1.55 m
Specifications	SJ3215 E	SJ3219 E
Extension Deck (Roll Out)	0.91 m	0.91 m
Ground Clearance (Pothole Raised)	8.9 cm	8.9 cm
Ground Clearance (Pothole Deployed)	1.3 cm	1.3 cm
Wheelbase	1.37 m	1.37 m
Weight	1,141 kg	1,468 kg
Gradeability	25%	25%
Turning Radius (Inside)	0	0
Turning Radius (Outside)	1.65 m	1.65 m
Lift Time (With Rated Load)	21 sec	22 sec
Lower time (With Rated Load)	18 sec	25 sec
Drive Speed (Stowed)	3.4 km/h	3.4 km/h
Drive Speed (Raised)	0.9 km/h	0.9 km/h
Maximum Drive Height	Full Height	Full Height
Capacity (Overall)	272 kg	227 kg
Distributed Capacity (Main Platform)	159 kg	114 kg
Distributed Capacity (Extension Deck)	113 kg	113 kg
Local Floor Load (With Rated Load)	1,093 kPa	1,159 kPa
Overall Floor Load (With Rated Load)	9.7 kPa	11.6 kPa
Maximum # of persons at 0 m/s wind rating	2	2
Maximum # of persons up to 12.5 m/s wind rating	1	1
Tyre Type	Solid, N/M	Solid, N/M
Tyre Size	12 x 4 x 8	12 x 4 x 8

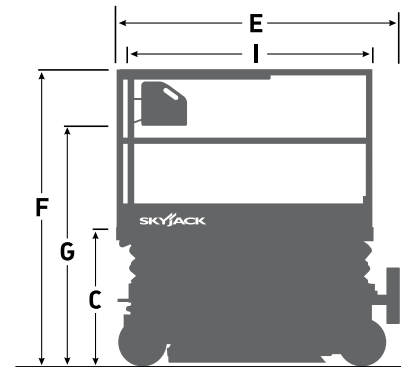
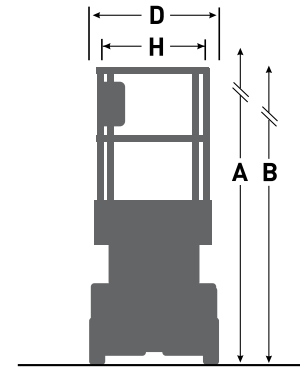

## ACCESSORYZERS<sup>‡</sup>

- Light duty pipe rack
- Heavy duty pipe rack
- Board carrier
- Tool caddy
- ECOTRAY leak containment system
- XStep
- Secondary Guarding Lift Enable (SGLE)
- Perimeter lights (Cannot be combined with dual flashing lights)

## OPTIONS<sup>†</sup>

- Dual flashing lights
- White noise alarm
- All motion audible alarm
- Wiring for AC outlet at platform
- 250 Ah Batteries
- AGM Batteries
- Lockable swingout trays
- Full height spring hinged entry gate
- Bio oil
- ELEVATE telematics (3-year or 5-year plans available)
- ELEVATE Battery Management System (BMS)\*

<sup>†</sup> Standard lead times may be increased when optional equipment is added, consult factory.  
<sup>‡</sup> Capacities and machine weights may differ when accessories and options are added.  
 \*Only available with ELEVATE telematics

[www.skyjack.com](http://www.skyjack.com)

Skyjack UK  
 Unit 1, Maes-y-Clawdd  
 Maesbury Road Industrial Estate  
 Oswestry, Shropshire, SY10 8NN  
 Tel: +44 1691 676235  
 Fax: +44 1691 676239  
 Email: [info@skyjackeurope.co.uk](mailto:info@skyjackeurope.co.uk)

Skyjack SAS (France)  
 74 Rue Sibert  
 F-42400 Saint Chamond  
 France  
 Tel: +33 (0) 4 78 73 53 32  
 Fax: +33 (0) 4 78 56 52 42

Skyjack Hebebühnen GmbH  
 (Germany)  
 Därmannsbusch 2a  
 D-58456 Witten  
 Tel: +49 (0) 2302 20 26 909  
 Fax: +49 (0) 2302 20 25 671

Skyjack AB (Sweden)  
 Agnesbergsvägen 28  
 424 38 Agnesberg  
 Sweden  
 Tel: +46 (0) 31 21 22 45  
 Fax: +46 (0) 31 787 65 10

**SKYJACK**  
 simply reliable